

3000 Series

SDH Microwave Radio Systems
For Long-haul Transmission
(4 to 11 GHz STM-1/OC-3)

INTRODUCTION

NEC's 3000 Series SDH (Synchronous Digital Hierarchy) Microwave Radio Systems are designed to provide high quality SDH radio network. They can operate in frequency bands from 4 to 11 GHz for long-haul transmission.

NEC's SDH Radio transmits one STM-1/OC-3 155 Mbit/s signal plus optional wayside signals.

The most efficient modulation techniques are used in full compliance with standard RF channel spacings as recommended by ITU-R.

30 MHz spacing : 128 QAM

40 MHz spacing : 64 QAM

Therefore, NEC's SDH radio systems allow users to continue operation without any modifications to existing frequency allocations.

SYSTEM ARCHITECTURE

Terminal station equipment provides an 155 Mbit/s interface. An optional 2 Mbit/s wayside signal, DCC/ E1/ E2 (SOH) signal and digital service channel (DSC) signal can be dropped and inserted at either terminal or repeater stations.

The system can be expanded to an N+1 protected system ($N \leq 11$). Moreover, the number of channels in the RF band can be further doubled by adopting dual polarization transmission in the long-haul system.

Dual polarization co-channel transmission can be realized with a fully digital cross polarization interference canceller (XPIC).

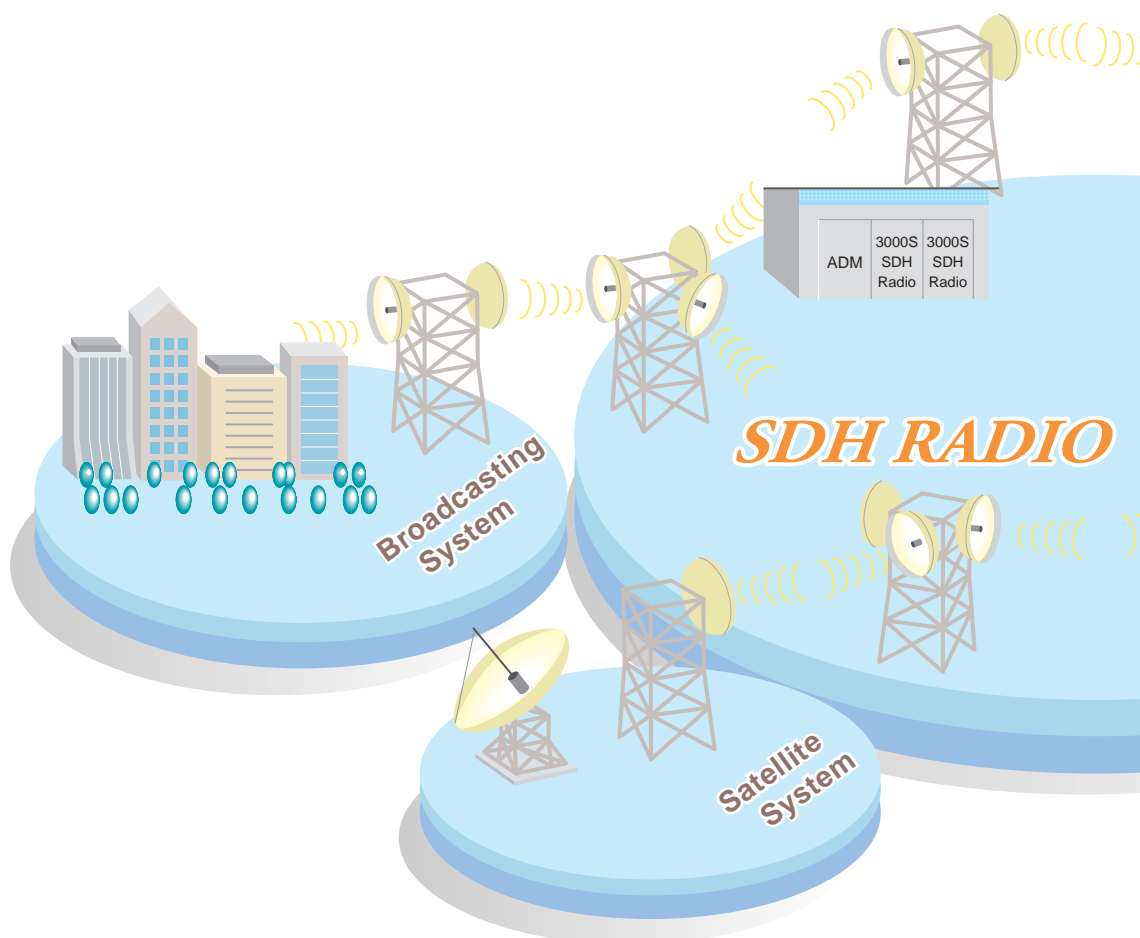

NEC's SDH Family

The SDH long-haul radio system is part of NEC's SDH Family, adopting the same single design concept. The SDH Family includes a wide variety of transmission systems, such as the add-drop multiplexer, as well as an NMS. This wide variety of systems opens up a full range of configurations for numerous applications. For example a self-healing SDH ring can be constructed by combining NEC's add-drop multiplexers and the 3000 Series SDH radio.

TMN Standard Compliant

Network Management features are designed in accordance with among others ITU-T Rec. M.3010 and G.784, and therefore enable interconnection with a TMN-based network management system (NMS).

Advanced Technologies

Throughout the SDH radio system, NEC's own advanced technologies are used. Intensive use of Microwave Integrated Circuits (MIC's) and Hybrid IC's (HIC's) makes the TRP durable and compact. Also, custom made large-scale integrated circuits (LSI's) are applied. For example, new digital MODEM is incorporated in a single LSI chip, specially developed by NEC. Furthermore, low-power high-speed complementary metal oxide semiconductor (CMOS) LSI's are extensively used, making the equipment more compact and highly reliable, which reduces the power consumption. Operation, Administration, Maintenance & Provisioning (OAM&P) performance and functionality are easily upgraded using software download facilities.

Total NEC Package

NEC can offer a complete transmission network system, including radio, multiplex and network management system. Complete factory integration, customer training, warranty and after sales support are available.

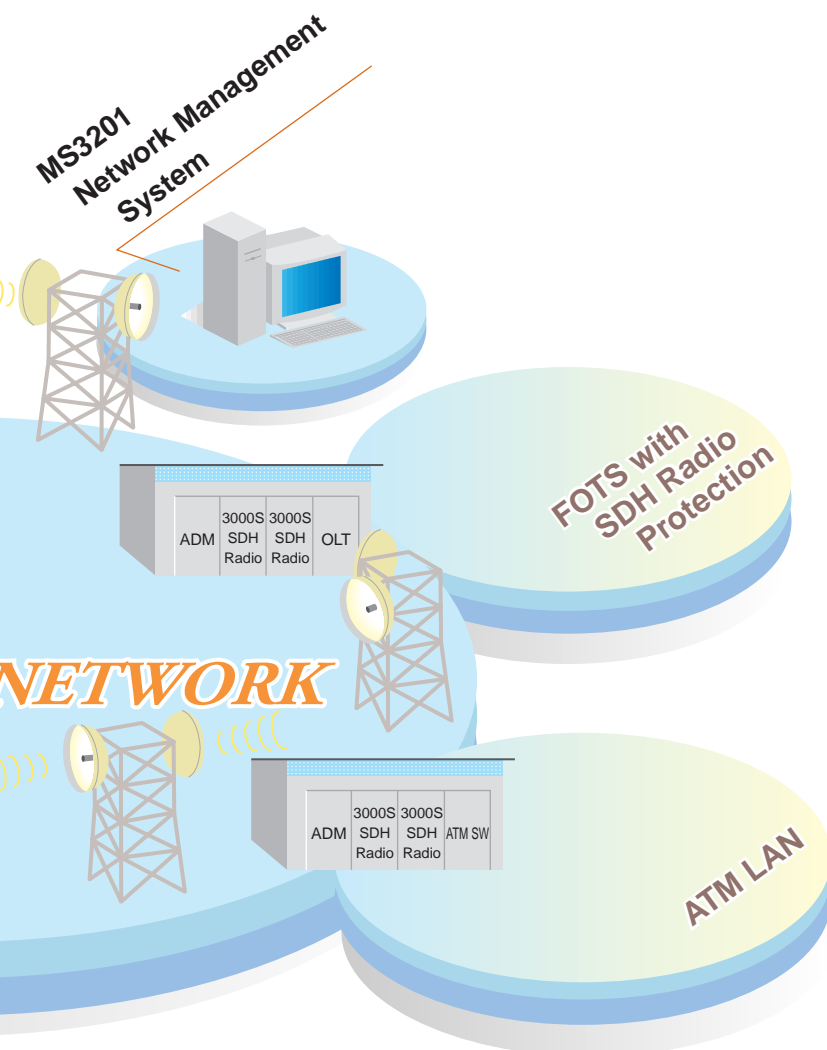

Fig.1 SDH Network Application

EQUIPMENT FEATURES

Conformity with the latest Standards

All NEC NE's are fully SDH compatible and conform to the relevant ITU-R and ITU-T Recommendations and European Telecommunications Standards (ETS).

Various System Applications and Easy Expandability

Various system applications such as N+1 Frequency Diversity (FD) protection switching system are available. The system can easily be expanded by adding modules and/or subracks to the existing configuration to increase transmission capacity. The maximum protected transmission capacity is 11+1. The N+1 protection switchover is hitless, therefore switchover operation is error-free.

Digital Modem

Fully digital modem with Decision Feedback Equaliser (DFE) is integrated into NEC's highly reliable customized LSI.

Better Error Performance with MLCM and MLCM+RS

Multi-Level Coding Modulation (MLCM) is applied to 128QAM systems and MLCM with Reed Solomon (RS) coding is applied to 64QAM systems. This ensures best error performance.

[MLCM]

- Low coding redundancy (It enables additional Wayside (WS) channel transmission.)

[MLCM+RS]

- Excellent coding gain
- Improvement of residual BER

Equalization

A high performance DFE effectively reduces inband dispersive amplitude and delay distortions caused by multi-path fading and comes as standard. It provides excellent minimum and non-minimum signature performance.

Automatic Transmit Power Control

Applying an Automatic Transmit Power Control (ATPC) system prevents interference to neighbouring systems, improves residual BER performance, alleviates upfade problems and reduces system power consumption. NEC's ATPC range is -12 to +2 dB.

Cross Polar Operation (Option)

Dual polarization co-channel transmission can be realised with NEC's fully digital cross polarization interference canceller (XPIC). This doubles the frequency efficiency and can be implemented for both 30 MHz and 40 MHz band plans.

Branching Filter Circuit (Option)

Contiguous type Branching Circuits (BR CKT) is most suitable filter circuit in case the following condition.

- Minimum adjacent frequency separation (30 MHz or 40 MHz)
- Maximum transmission capacity (Dual polarization co-channel transmission)

The contiguous type BR CKT eliminates the need for an RF hybrid that would be required for the minimum adjacent frequency separation using a circulator type BR CKT.

Space Diversity IF Combiner

The SD IF combiner incorporates both In-Phase (IP) and Minimum In-band Dispersion (MID) combining. MID can suppress in band dispersion.

The IF combiner also provides inbuilt delay electrical DADE.

STM-1 Interface Options

The system can be equipped with an electrical or an optical STM-1 interface for each channel.

The optical interface is available for two different cable length: intra-office or long-haul inter-office applications.

Redundancy for Optical Interface (Option)

Redundant (1+1) optical interface is available for each radio bearer. Required when connecting to a protected FOTS or another NEC's terminal radio for extra system availability.

Redundancy for Electrical Interface (Option)

For STM-1 electrical interface, all radio bearers come with a main and standby code conversion card with a bipolar switch. This ensures greater radio interface reliability and better overall system availability in the network.

Digital Service Channels and Wayside Traffic

In addition to the main traffic signal, 1 x (192 kbit/s or 64 kbit/s) + 4 x 64 kbit/s DSC's and one or two (2 or 1.5 Mbit/s) WS channel(s) can be dropped and inserted at any terminal and repeater radio station. These channels are transported in the RFCOH.

Alarm, Status and Performance Monitoring

Built-in OAM&P facilities enable monitoring and control of external equipment such as housekeeping facilities via a parallel interface. Performance monitoring is built-in, including:

- Performance parameters as in ITU-T G.826.
- Registration of the number of protection switchover operations (for 1+1 and N+1)
- Accumulation of the failed time for individual regular channels.

The operator can perform monitoring and control functions, by using the LCT (Local Craft Terminal), or by using the MS3201 Network Management System (NMS).

BAY CONFIGURATION

Fig. 2 shows the physical layout of a long-haul system. A complete 3+1 terminal system can be mounted within an ETSI rack.

This system comprises four transmitter-receivers with the option of space diversity, four modulator-demodulators with SDH interface, an OAM&P, switch units, an IDB (Interface Distribution Board) and an RF branching circuit.

Even if the racks are fully mounted, no forced cooling of the equipment is required.

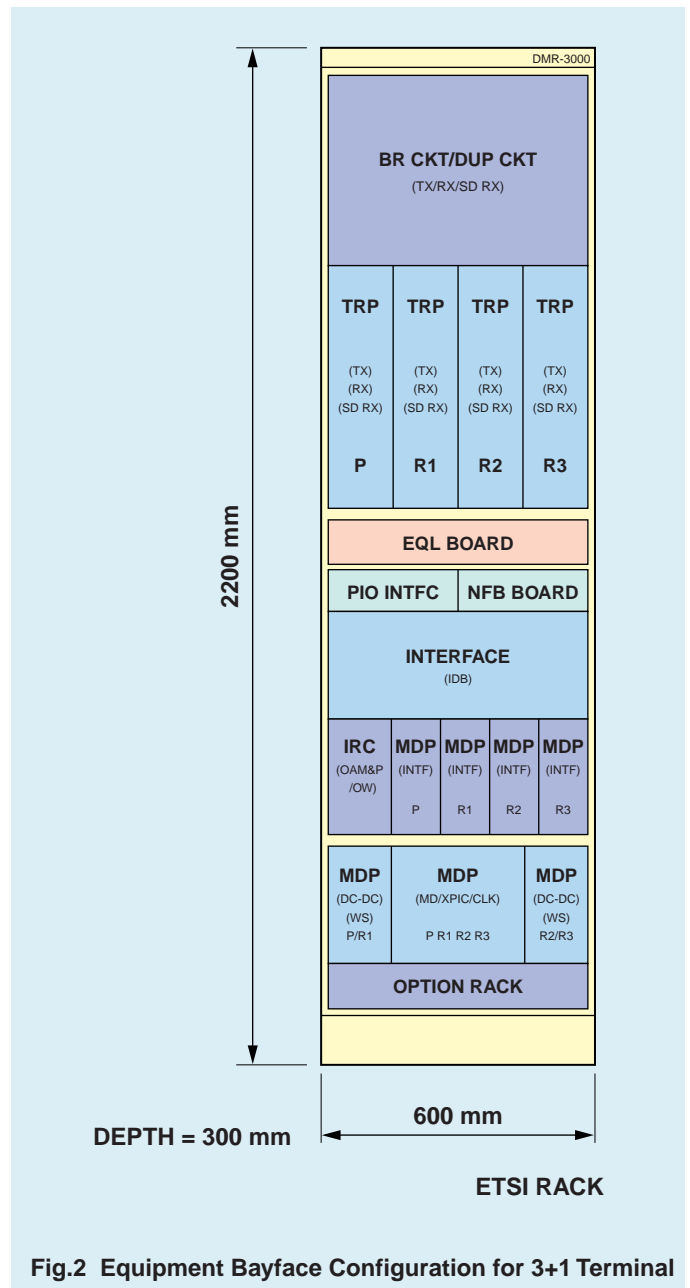

Fig.2 Equipment Bayface Configuration for 3+1 Terminal

MS3201 NETWORK MANAGEMENT SYSTEM

Introduction

The MS3201 is a fully integrated network management system for NEC's SDH radio and multiplex equipment.

Overall System Configuration

The MS3201 can support the following SDH equipment and network configuration.

- The SDH NE can comprise of NEC's SDH radio (2000S or 3000S) and SDH FOTS (SMS 150V, SMS 600V) equipment.
- The network configuration can be a linear and/or ring connection comprising of radio and FOTS NE.
(SNC-P: Sub Network Connection Protection with Path)
- Line Protection can comprise of N+1 radio section protection, Twin Path Radio protection and FOTS Line Protection.

Features

Common Platform

Integrated management of SDH radio, SDH Mux and SDH FOTS on a common platform

Flexible scalability

Manage small or large network (max.: 120 Network Elements (NE))

Standardization

The TMN complies with M.3010 Principle for a Telecommunication management network.

- Q.811 Lower Layer Protocol Profiles Q3 interface
- Q.812 Upper Layer Protocol Profiles Q3 interface
- M.3100 - Generic Network Information Model The SDH G. 784 - Synchronous Digital Hierarchy (SDH) Management

OAM&P

The MS3201 provides the following TMN concepts performing the Operation, Administration, Maintenance and Provisioning Function.

1. Fault Management includes:
Network Alarm Monitoring, NE Status Monitoring, Current Event List, Event History and Event Filtering (date, target object, event type, severity).
2. Performance Management includes:
Performance Data Display, Scheduled performance data retrieval (from NE), Quality of service (QOS) monitoring and Quality of service (QOS) threshold setting.
3. Configuration Management includes:
Building of overall network view, Provisioning of network element, Protection switching, Path management and Maintenance Functions.
4. Security Management includes:
User registration, Assignment of user privilege and Logging of security related actions.

Open Interface

Use of Q3 interface between Manager and Radio NE.
Use of Qx interface between Manager and MUX/FOTS NE. Qnn interface to upper Network Management Layer (based on ETS 300 653/future plan).

Refer to Fig. 3.

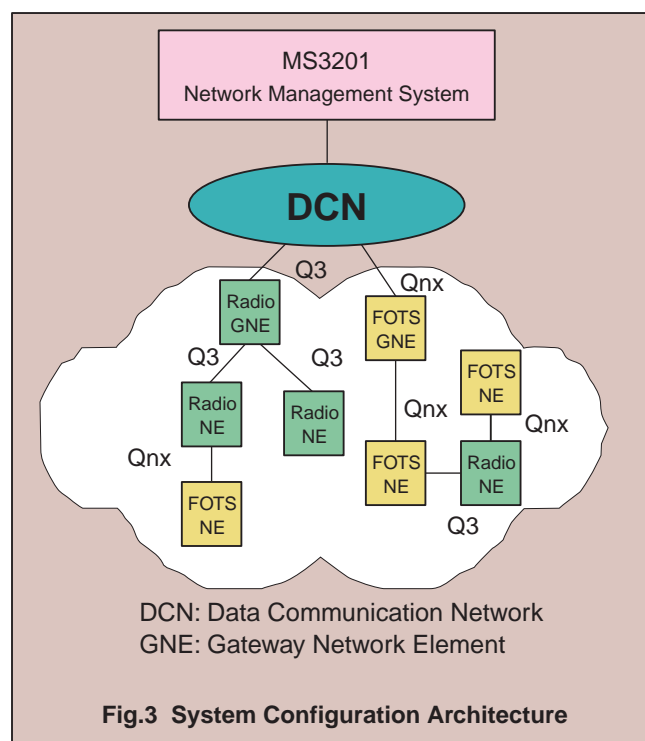

The NMS consists of:



Operator Terminal

- Provides GUI driven functions. One operator terminal can communicate with multiple servers. One server can support multiple operator terminals.
- A typical operator terminal hardware comprises of a IBM PC or equivalent.



Server

MIB (Information about Managed Objects (MO) of SDH NEs). NE communication and unifies the data exchange between each NE type. CORBA/X Window communication with operator terminals. Qnn Communication provides an interface to an upper level NML. (future plan)

A typical server hardware comprises of a SUN Ultra60 Model 250 or equivalent.

- Redundancy of server (future plan)
In case of failure of the working server, the system automatically switches to the stand-by server.

Specifications

The NMS specifications are:

- Maximum number of servers is 10.
- Maximum number of operator terminals is 16. (Each NE is registered in max. 8 operator terminals.)
- Maximum number of NEs managed by one server is 120.
- Server to Remote Operator Terminal uses a G.703 or V.35 - 2 Mbps (minimum).
- Server to GNE uses G.703 or V.35 - 2 Mbps.

Operator/Server Configuration

The MS3201 can be configured as:

- 1) Multi-operator terminal per server

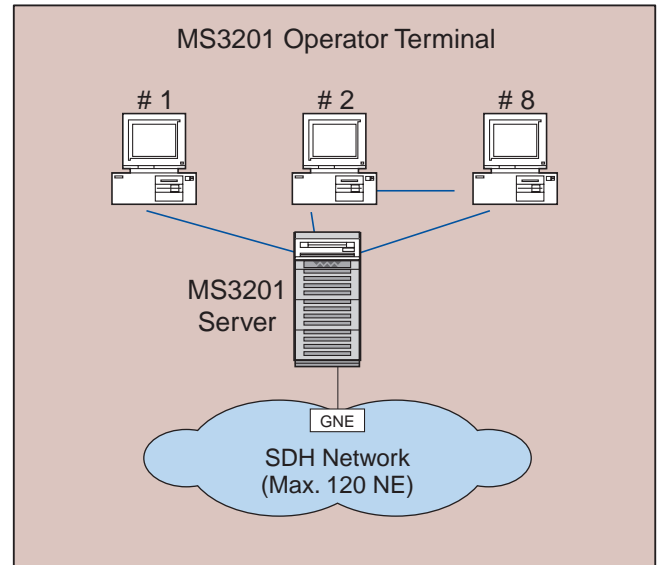

- 2) Multi-operator terminal/Multi-server (Future Plan)

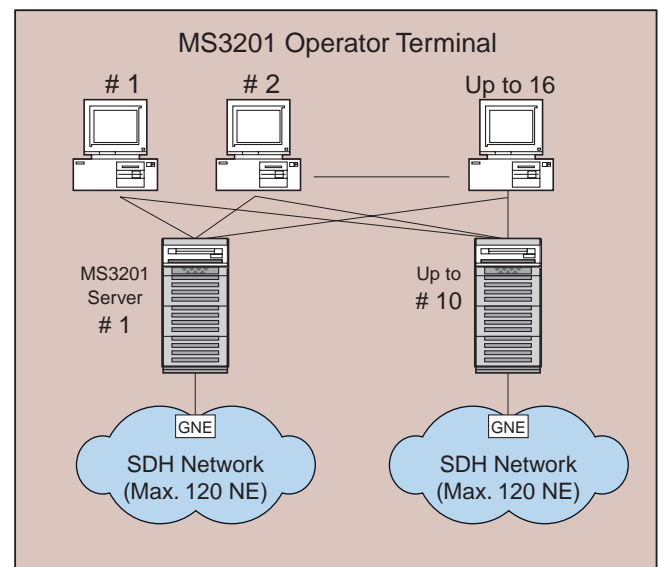

System and Equipment Parameters

System Parameters (64QAM)

Radio Frequency	4 GHz	5 GHz	U6 GHz
Frequency Range	3,600 - 4,200 MHz	4,400 - 5,000 MHz	6,430 - 7,110 MHz
Channel Spacing	40 MHz	40 MHz	40 MHz
Modulation Scheme	64QAM MLCM + RS		
TX Output Power (excluding BR CKT Loss)	33 dBm	33 dBm	33 dBm
System Gain at BER=10 ⁻³ (excluding BR CKT Loss)	109.1 dB	109.1 dB	109.1 dB

Radio Frequency	8 GHz	11 GHz
Frequency Range	7,725 - 8,275 MHz	10,700 - 11,700 MHz
Channel Spacing	40.74 MHz	40 MHz
Modulation Scheme	64QAM MLCM + RS	
TX Output Power (excluding BR CKT Loss)	33 dBm	30 dBm
System Gain at BER=10 ⁻³ (excluding BR CKT Loss)	108.6 dB	105.6 dB

System Parameters (128QAM)

Radio Frequency	4 GHz	L6 GHz	7 GHz
Frequency Range	3,803.5 - 4,203.5 MHz	5,925 - 6,425 MHz	7,125 - 7,725 MHz
Channel Spacing	29 MHz	29.65 MHz	28MHz
Modulation Scheme	128QAM MLCM		
TX Output Power (excluding BR CKT Loss)	32 dBm	32 dBm	32 dBm
System Gain at BER=10 ⁻³ (excluding BR CKT Loss)	105.7 dB	105.7 dB	105.2 dB

Radio Frequency	8 GHz
Frequency Range	7,725 - 8,275 MHz
Channel Spacing	29.65 MHz
Modulation Scheme	128QAM MLCM
TX Output Power (excluding BR CKT Loss)	32 dBm
System Gain at BER=10 ⁻³ (excluding BR CKT Loss)	105.2 dB

System Parameters

Transmission Capacity	STM-1 or OC-3 (155.520 Mbit/s, electrical or optical interface)
Wayside Capacity (in RFCOH)	64QAM System: 2 x 2.048 Mbit/s or 2 x 1.544 Mbit/s 128QAM System: 1 x 2.048 Mbit/s or 2 x 1.544 Mbit/s
Service Channel Capacity (in RFCOH)	1 x (192 or 64 kbit/s) and 4 x 64 kbit/s
Power Supply Requirement	-48V DC (-36 to -72V DC)/-24V DC (-20 to -35V DC)/ +24V DC (+20 to +35V DC)
Total Power Consumption	Approx. 315W (for 4-U6 GHz, 1+1 Terminal, 10W FET type, e/w SD)
Mounting Rack	ETSI - Rack
Dimensions (W x D x H)	600 x 300 x 2,200 mm
Operating Temperature (Guaranteed)	-5°C to +50°C

Specifications are subject to change without notice.